

SCHUCK COLLECTORS AND DISTRIBUTORS

Custom-built fittings for use in pipelines and plant constructions.

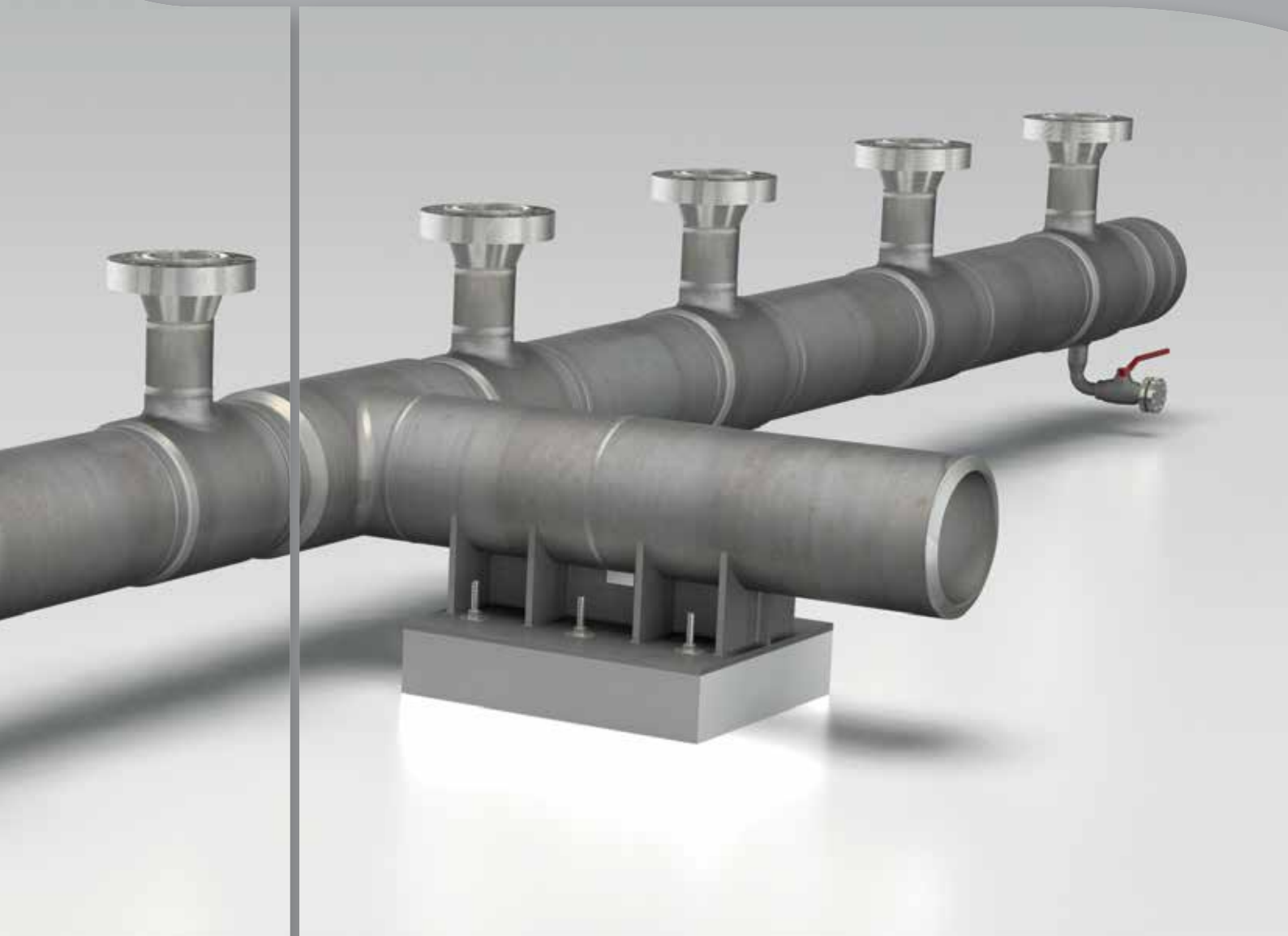
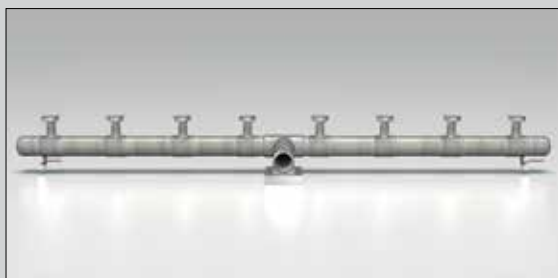

SCHUCK COLLECTORS AND DISTRIBUTORS

Custom-built fittings for use in pipelines and plant constructions.



APPLICATIONS

- Gas, gaseous and liquid media
- Temperature range -10°C to $+50^{\circ}\text{C}$
- Special design -40°C to $+150^{\circ}\text{C}$
- Installation under and above ground
- Nominal widths up to DN1600
- Operating pressure up to PN230
- Other applications areas on request

MANUFACTURING AND TESTING

- DIN 2470 Part 1
- DVGW Worksheet G 463
- TRFL
- ASME Code and other international standards or specifications
- Customer specification
- Certificates EN 10204, 3.1 and 3.2



PRODUCT FEATURES

- » Customized individual solutions by customer request
- » Design, calculation construction and production from a single source at Schuck
- » Realization of nominal widths up to 60"
- » Max. nominal pressure 230 bar
- » Primarily used for gas, but can also be used for other media
- » Because of various processing and testing equipment many possible corrosion protection systems



DESIGN

With hot collared pipe connectors

With welded-on pipe connectors

Single molded parts or distribution systems with multiple collars or branches (header and so on)

With pig deflectors on request

Outlet side available with flange or welded ends

STANDARD MATERIALS

Standard materials

≤ PN16 as per DIN 2470 Part 1
> PN16 as per G463

Pipes

L360NB as per EN 10208
L290 NB as per EN 10208

Sheet metal

P355 NH/NL1 as per EN 10028-3
P460 NH/NL1 as per EN 10028-3

Other materials

according to standard, specification or customer specification on request

SCHUCK COLLECTORS AND DISTRIBUTORS

Custom-built fittings for use in pipelines and plant constructions.

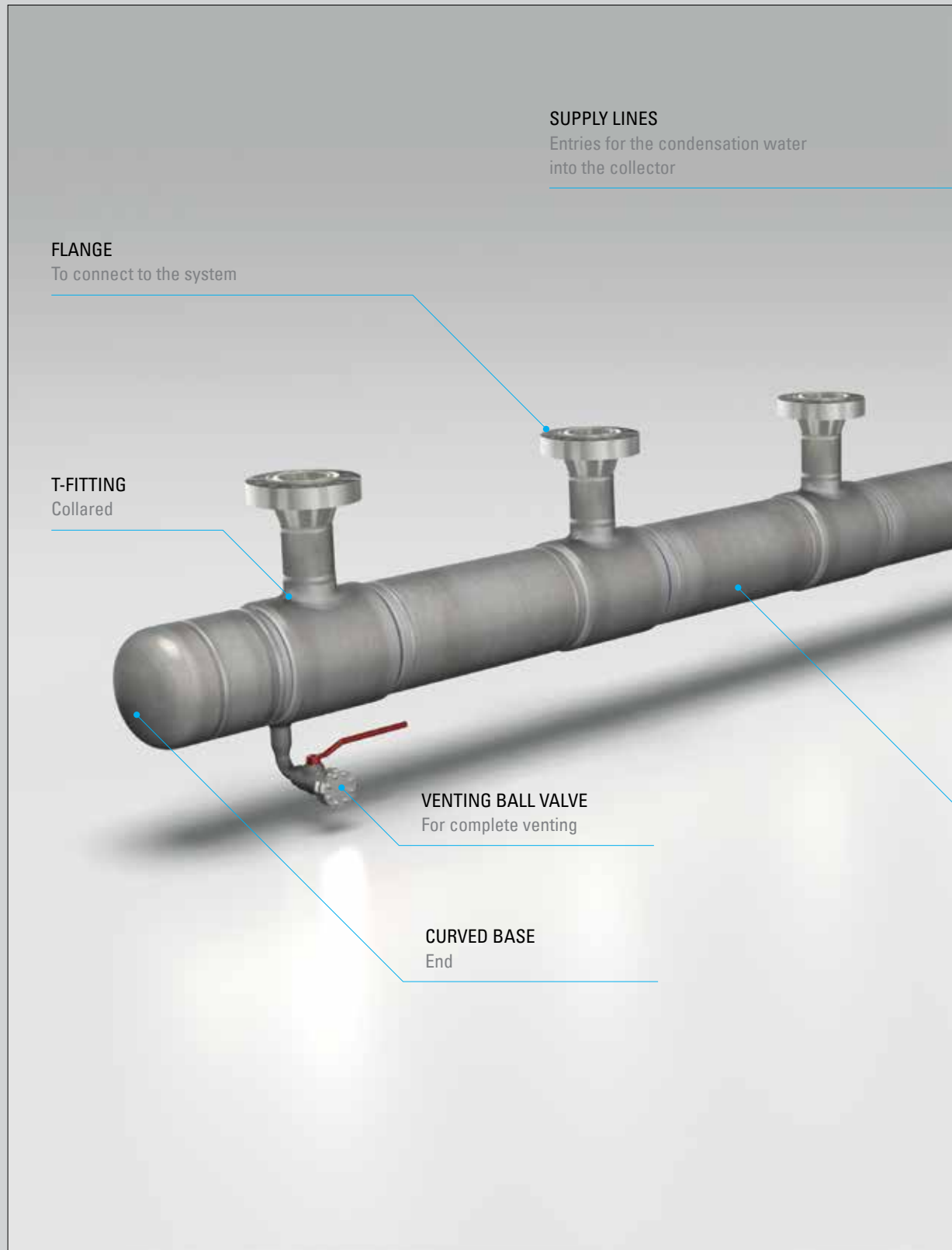

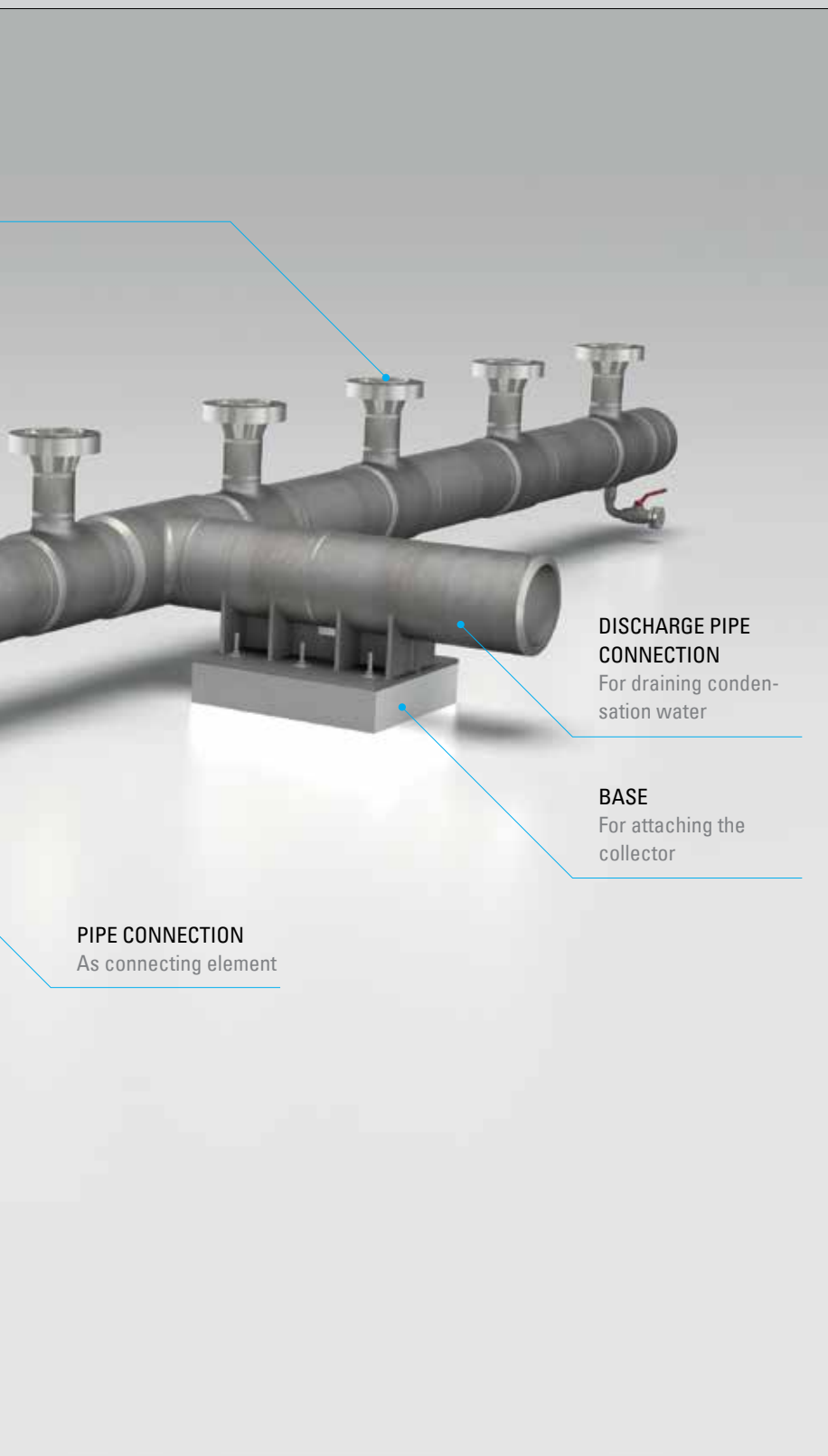

SCHUCK COLLECTORS AND DISTRIBUTORS CUSTOM-BUILT FITTINGS FOR USE IN PIPELINES AND PLANT CONSTRUCTIONS.

Schuck custom-built fittings such as collectors and distributors fulfill the requested tasks in pipeline and plant construction. Besides customer-specific requirements, the products also meet all manufacturing and testing conditions from the specified rule groups.

Due to high vertical integration, the molded parts are not only developed and designed completely in-house, but they are also completely manufactured. This guarantees a reliable product from a single source for our customers.

Schuck custom-built fittings are available in numerous designs so that they can be optimally matched to customer specifications. They range from collared to welded connections up to complete distribution systems.

Custom fittings can be installed both above ground as well as below ground. Different coating components are available from Schuck for safe use.

DISCHARGE PIPE CONNECTION
For draining condensation water

BASE
For attaching the collector

PIPE CONNECTION
As connecting element

SCHUCK FREE SPACE

Room for your notes







SCHUCK GROUP

Franz Schuck GmbH
Daimlerstraße 5-7
89555 Steinheim, Germany

Fon +49. (0) 7329. 950 -0
Fax +49. (0) 7329. 950 -161

info@schuck-group.com
www.schuck-group.com

We manufacture and distribute components for connecting pipeline systems in more than 50 countries, with 5 international offices and over 40 years of experience.

Do you want to find out more about a specific product?
Give us a call, or visit to our website at www.schuck-group.com.