

---

**SCHUCK ACTUATOR SYSTEMS**

Flexible actuator and control systems for 90° travel with  
Scotch-yoke principle for torques up to 600,000 Nm.



# SCHUCK ACTUATOR SYSTEMS

Flexible actuator and control systems for 90° travel with Scotch-yoke principle for torques up to 600,000 Nm.

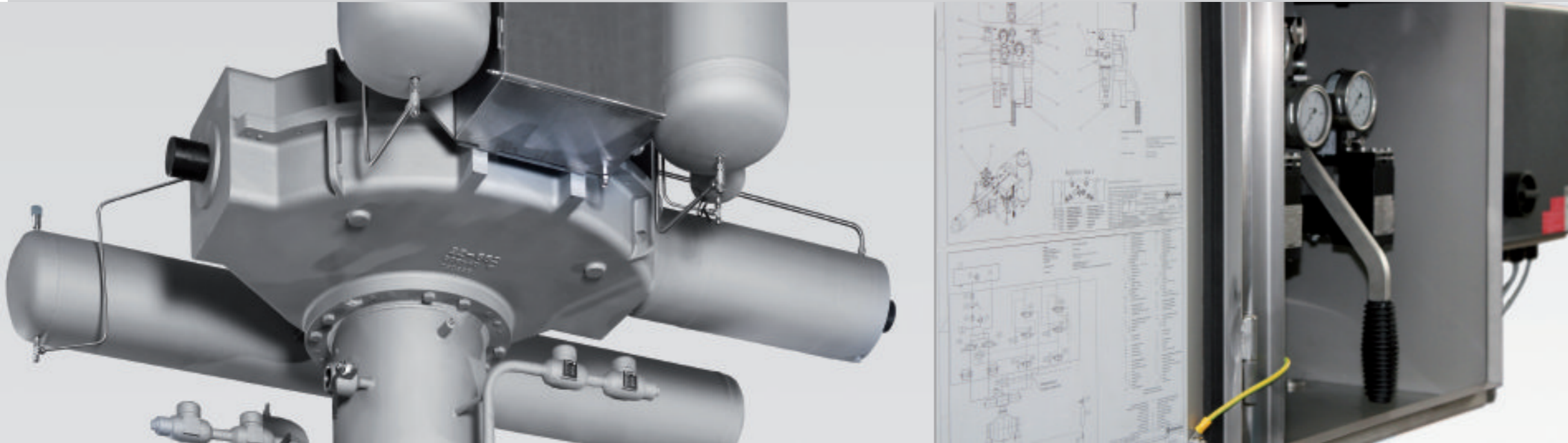

## PRODUCT BENEFITS

- » Optimal adjustment of the torque curve through the Scotch-yoke principle
- » Precise, proportional position indicator over the entire travel range
- » Atmospherically ventilated basic actuator
- » Stops for precise adjustment of the pivoting movement and to handle the max. output torque
- » Maintenance-free thanks to plastic-coated bearings
- » Modular system with in-stock components



## APPLICATIONS

All versions suitable for Ex Zone I  
 Ambient temperature -60 °C to +80 °C  
 Output torque up to 600,000 Nm  
 Suitable for all fittings with 90 ° swivel angle of all manufacturers



## PRODUCTION AND TESTING

Casing and yoke made of resistant and ductile spheroidal iron GGG 40 with good dry-running properties. The casing and yoke can also be manufactured from carbon steel for temperatures down to -60 °C and on customer request.  
 Extensive factory testing of the actuator with the valve ensures trouble-free operation for the customer.



## DESIGN

Manual actuators with hand wheel  
 Electric actuators with e-motor and hand wheel  
 Hydraulic actuators with hydraulic cylinder  
 Pneumatic actuators with pneumatic cylinder

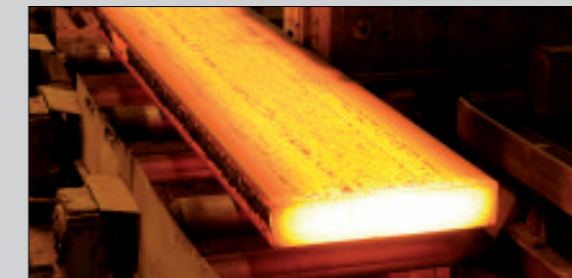

## MATERIALS

**Basic actuator and casing**  
 GGG-40 or carbon steel  
**Yoke**  
 GGG-50 or steel  
**Control cabinet, fittings, pipes**  
 Stainless steel  
**Control block**  
 Aluminum hard-coated

# SCHUCK ACTUATOR SYSTEMS

## Type overview



### MANUAL ACTUATION

VG – GG 00/31, 00/41

Schuck manual actuators are available in different versions with an output torque of up to 600,000 Nm. The actuators are designed to be operated manually without great physical effort. Conversion or retrofitting according to customer requirements is possible at any time.

All Schuck manual actuators can also be equipped with electric end position signaling. All electrical components are suitable for Ex Zone I.



### ELECTRIC ACTUATION

VG – GG 00/32, 00/42

Schuck electric actuators are available in different versions with an output torque of up to 600,000 Nm.

These actuators are equipped with a hand wheel for emergency actuation. The attached electric actuator can be very small thanks to the high efficiency of the basic actuator.

The actuating time is variable and can be implemented according to customer requirements. Conversion or retrofitting according to customer requirements is possible at any time.

All Schuck electric actuators can also be equipped with electric end position signaling. All electrical components are suitable for Ex Zone I.

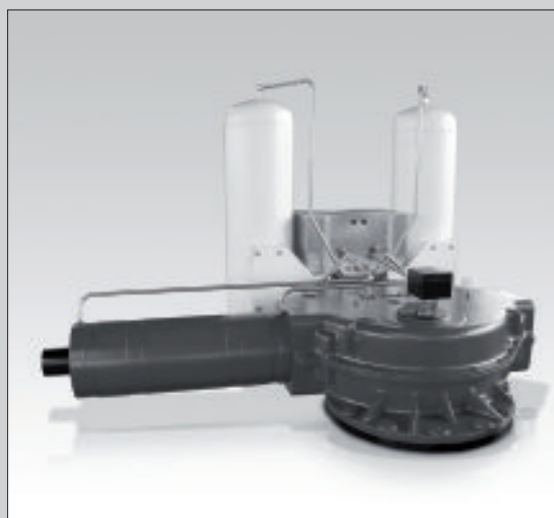

### CYLINDER ACTUATOR, DOUBLE-ACTING

VG – GG 00/11, 00/12

Hydraulic/pneumatic cylinder actuators are available in different versions with an output torque of up to 600,000 Nm. Hydraulic/pneumatic actuators are always operated via a corresponding control. This control is housed in a control cabinet, which is mounted right next to the actuator.

The configuration of the control may be customized. Remote control signals, additional signal receptors, and additional equipment such as limit switches can be added or retrofitted at any time.

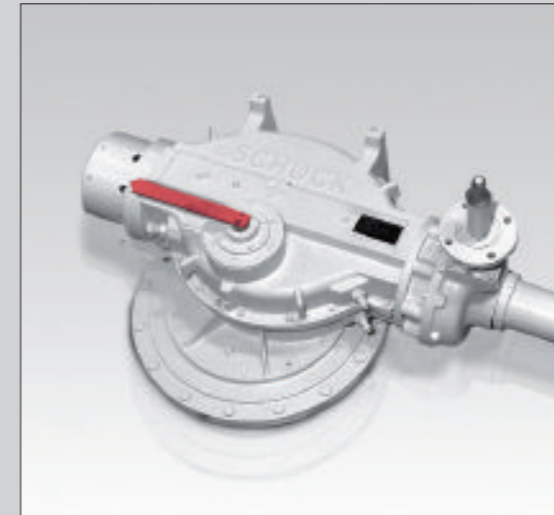

### SUBSEA ACTUATORS

VG – GG 00/31/P, 00/41/P, 00/11/P

Schuck subsea actuators are designed to be mounted on the valve under water. For this type of use, the actuator is sealed to the outside and completely filled with biodegradable oil. A pressure compensation device is provided to match the actuator's internal pressure to the external water pressure. This actuator can be used at any depth. An external mechanical position indicator is available, and all parts that come in contact with water are made from stainless steel. Potential leaks on the neck seal of the fitting are diverted via a pressure relief valve. The actuator can also be equipped with limit switches. Underwater actuators are also maintenance-free, just like all Schuck actuators.



### CYLINDER ACTUATOR, SPRING RETURN

VG – GG 12/15, 15/12, 15/11, 11/15, 00/19, 19/00

Actuators are also available with spring return in different versions with an output torque of up to 600,000 Nm. Actuators with spring return are operated via a pneumatic or hydraulic control. This control is housed in a control cabinet, which is mounted right next to the actuator.

If the operating power fails, the actuator moves into the „safe“ position via the spring. Remote control signals, additional signal receptors, and additional equipment such as limit switches can be added or retrofitted at any time. All actuator systems are optionally equipped with a hydraulic manual override.



### PLANETARY GEAR

Schuck planetary gear features a modular design and provides an output torque of up to 4,000 Nm. The control rod of the Schuck planetary gear is located directly above the pipe axis. The actuator is designed in accordance with DIN 5211 as standard, but it can also be customized. The end stop is located in the gear unit. It can be operated via a hand wheel for above ground installations or with a switching extension for underfloor situations. The gear unit can also be supplied with a torque arm for shaft mounting. In addition, the planetary gear can be operated with an electric motor, which can be optionally equipped with a limit switch. The gear unit has a precise fit and is very efficient thanks to the use of high-quality materials and precise manufacturing. Provided with a grease filling, it is maintenance-free.

# SCHUCK BASIC ACTUATOR

## Modular system and Scotch-yoke principle

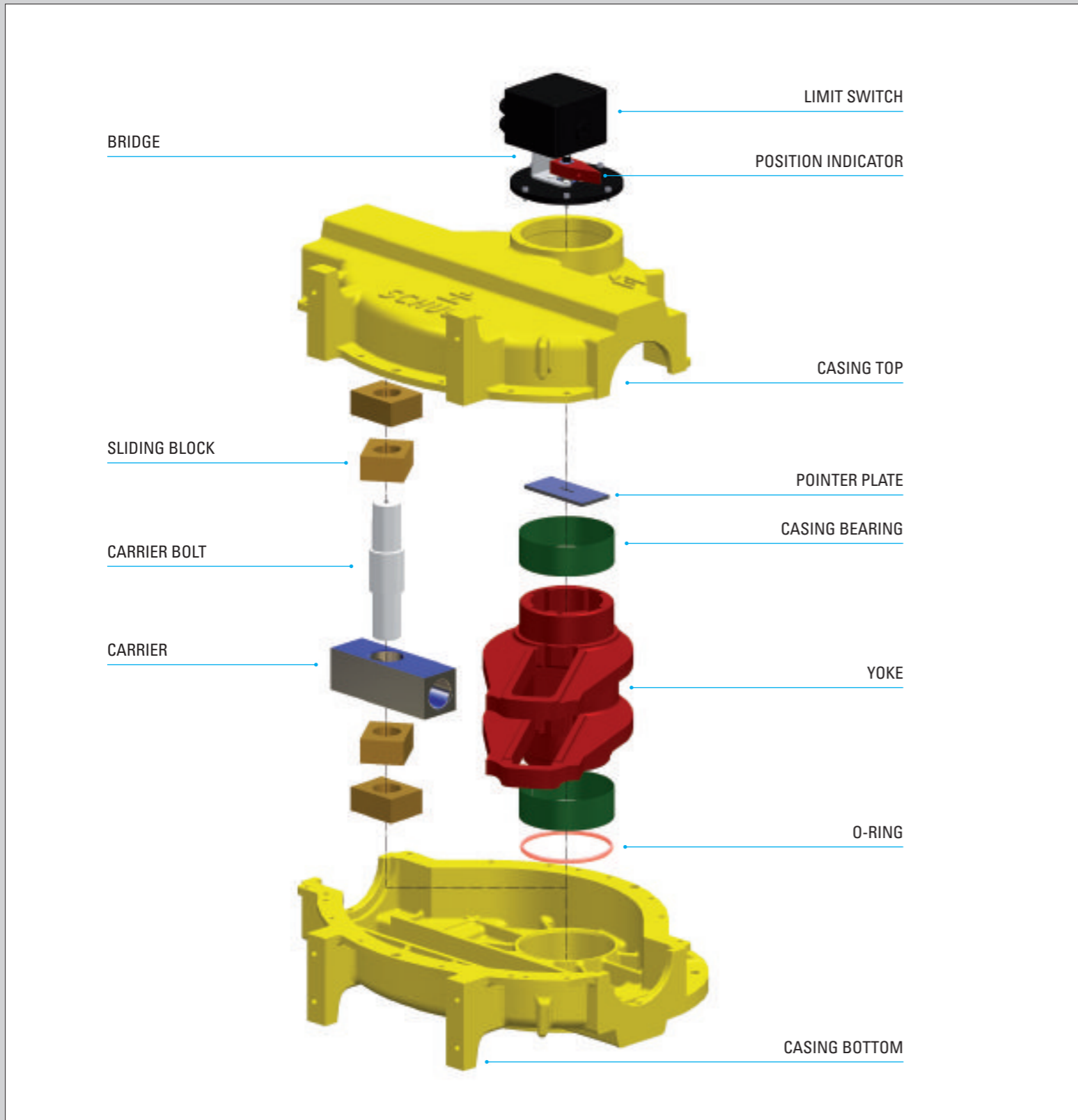

Basic actuator versions	
Type	Torque
VG	2,000 Nm
WG	4,000 Nm
AG	8,000 Nm
BG	20,000 Nm
CG	40,000 Nm
DG	85,000 Nm
EG	150,000 Nm
FG	350,000 Nm
GG	600,000 Nm

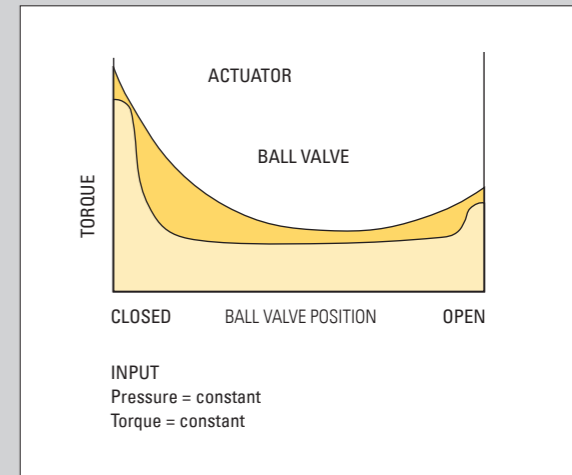

Basic curve of actuator and ball valve torque

### Modular system

Schuck actuators for a 90° travel range have been designed as a modular system. The basic actuator is the foundation. Eight different sizes of basic actuators with output torques of up to 600,000 Nm are available. The basic actuator consists of a lower and upper casing containing the pivoting yoke. Both parts are made from robust and ductile cast iron. Optional carbon steel casings and yokes are available. The basic unit together with the attachments forms a complete, fully functioning actuator. The choice of attachments is determined by the required input energy. The input energy can be applied either manually, hydraulically, pneumatically, or electrically. Universal attachment points are provided on both the right and left sides, thus enabling the use of the various designs of pivoting actuator, either manual, electrical, hydraulic or pneumatic, with the option of a spring return. The modular system permits retrofitting at any time.

### Scotch-yoke principle

The linear input movement of, for example, a hydraulic cylinder, is converted into the required 90° pivoting movement by means of the sliding blocks and guide track, in accordance with the Scotch-yoke principle. The linear movement of the attachments acts on the lever arm of the yoke via the carrier, the carrier bolt, and the sliding blocks.

The advantage of the Scotch-yoke principle is that the output torque is adjusted to the ball valve at a constant input torque or input pressure.

With their very limited friction, Scotch-yoke actuators are highly efficient and permit a very compact design. The actuators are self-locking and jerk-free.

All bearings are dry-running and plastic-coated, and do not require any lubrication with grease or oil. The internal parts are only greased to protect against corrosion. The basic element is maintenance-free. The actuator has a very long working life.

Each actuator is fitted with a mechanical position indicator. The proportional position of the ball valve is indicated throughout the entire actuator travel range.

The pivoting action is limited by stops which are set up in accordance with the maximum torque. The actuator stops absorb the maximum input torque and maximum input force.

# SCHUCK ACTUATOR SYSTEMS

## Basic actuator type code

### Attachments left



### 00 - Blind/adjusting flange



### 11 - Hydraulic cylinder



### 12 - Pneumatic cylinder



### 15 - Spring cylinder



### 19 - Pneumo spring cylinder



### ADDITIONAL ATTACHMENT L

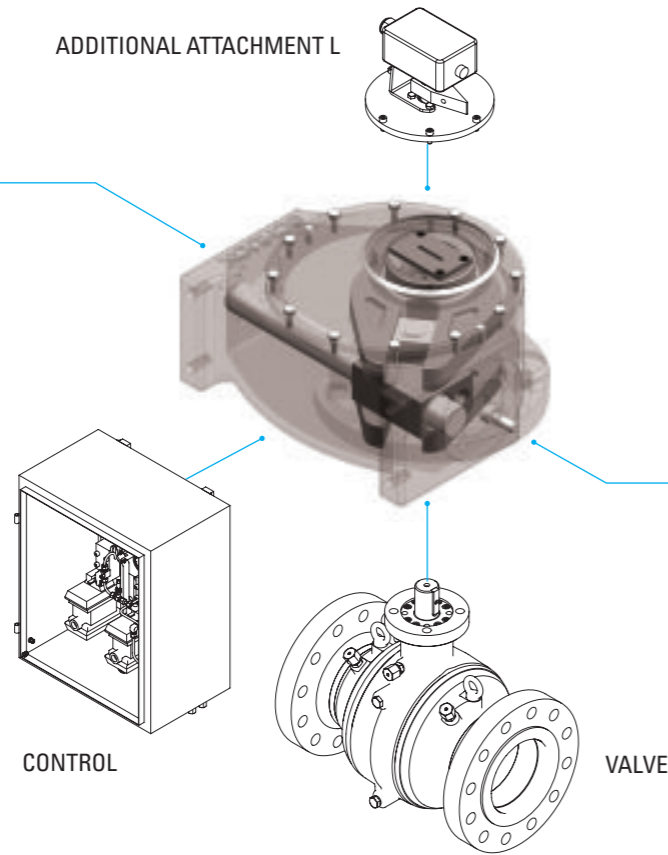

### Basic actuator (code table)

Torque		L	/	R	Detail L	/	Detail R
1,000 Nm	VG		/			/	
4,000 Nm	WG		/			/	
8,000 Nm	AG	12	/	15	400	/	96
20,000 Nm	BG		/			/	
40,000 Nm	CG	31	/	00	56PFH600	/	
85,000 Nm	DG		/			/	
150,000 Nm	EG		/			/	
350,000 Nm	FG		/			/	
600,000 Nm	GG		/			/	

### Examples

AG	12	/	15	/	400	/	96
8,000 Nm	Pneumatic cyl.		Spring cyl.		Gas cyl. ø		Spring force 96,000 N
CG	31	/	00	/	56PFH600		
40,000 Nm	Gear, handwheel		Blind flange		Gear type, transmission ratio, option		

### Attachments right



### 00 - Blind/adjusting flange



### 11 - Hydraulic cylinder



### 12 - Pneumatic cylinder



### 15 - Spring cylinder



### 19 - Pneumo spring cylinder



# SCHUCK ACTUATOR SYSTEM TYPE G

## Gas over oil

Left: Actuator with control for a 48" ball valve

Right: Control Type G with remote control OPEN/CLOSE, incl.  
 - Torque limiter  
 - Locking device (OPEN)  
 - ESD solenoid valve with manual reset

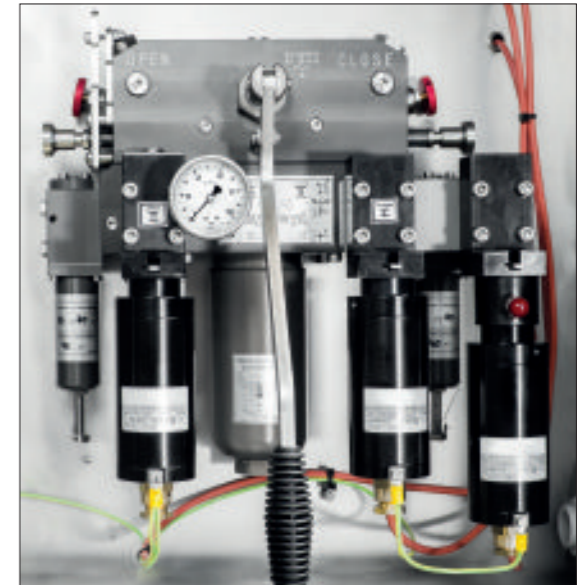

### Product benefits

- The compact design results in very few pipelines and screw fittings
- Small gas-over-oil containers
- Emergency manual operation with hand pump
- Automatic reset to normal operation after emergency manual operation (no risk of incorrect operation)
- Manual control on site
- Remote control
- Low-maintenance thanks to self-cleaning / self-ventilating oil circuit
- Electric control voltage on request
- The modular system permits one or several different signal processing methods and additional attachments
- Locking device in OPEN or CLOSED position (optional)

### Testing

Extensive testing of the actuator with the valves ensures trouble-free operation.

### Application

- Offshore/onshore, stations, line blocking devices and safety isolating valves
- All models for Ex Zone I
- Ambient temperature -60 °C to +80 °C
- Operating pressure 2 to 12 bar (pneumatics), 10 to 150 bar (high pressure)

### Design

- Standard with manual override
- Operated with own medium
- Automatic pipe fracture response (optional)
- With power cut (ESD/optional)
- Also with pressure vessels according to ASME or PED

### Manufacture

- Control made from seawater-resistant materials
- Pipework and screws made of stainless steel
- Compact, lockable, and seawater-resistant control cabinet

## SCHUCK ACTUATOR SYSTEM TYPE K

Simple pneumatic function with spring return

Left: Spring-opening actuator with control



Right: Type K control with two solenoid valves (1x ESD), differential pressure valve and on-site switch



**Product benefits**

- Safe travel to safety position via spring
- Can be used in safety systems SIS to SIL 3
- All control components in stainless steel or high-grade aluminum
- Use of standard components from internationally renowned manufacturers
- Compressed air or gas version
- High-pressure or low-pressure version
- Quick-lock version possible
- Low-temperature version possible

**Testing**

Extensive functional testing of the actuator with the valve ensures faultless operation.

**Application**

- Offshore/onshore, stations, line blocking devices and safety isolating valves
- All models for Ex Zone I
- Ambient temperature -60 °C to +80 °C
- Operating pressure 2 to 16 bar (pneumatics), 10 to 150 bar (high pressure)
- Quick-lock < 15 s to 48" possible

**Design**

- Operated with own medium
- Operated with compressed air
- With power cut (ESD)
- Also with pressure vessels according to ASME or PED

**Manufacture**

- Control made from seawater-resistant materials
- Pipework and screws made of stainless steel and seawater-resistant control cabinet

## SCHUCK ACTUATOR SYSTEM TYPE KY

Hydropneumatic

Left: Actuator with control for 32" ball valve

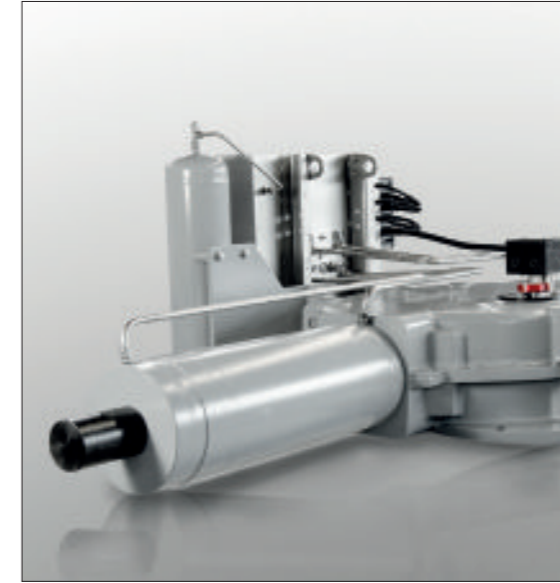

Right: Type KY control with remote control OPEN/CLOSE, incl. - Torque limitation - Automatic pipe fracture response with manual reset and optional adjustment set

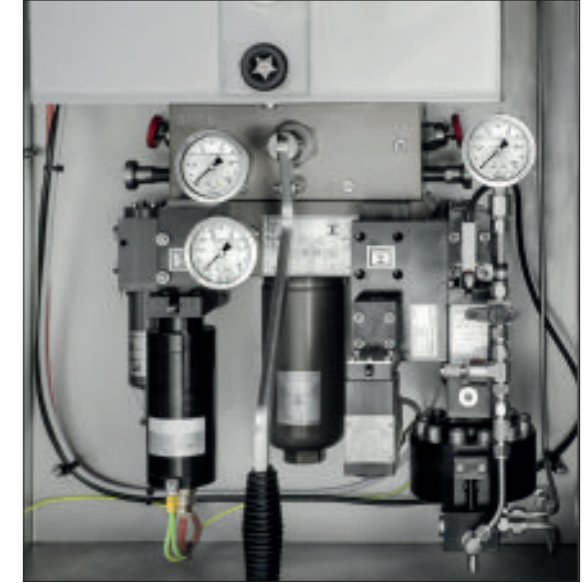

**Product benefits**

- The compact design results in very few pipelines and screw fittings
- Integrated seawater-resistant oil return tank with unpressurized, permanent oil level indicator
- Emergency manual operation with hand pump
- Automatic reset to normal operation after emergency manual operation (no risk of incorrect operation)
- Low gas consumption
- Manual control on site
- Remote control
- Low-maintenance thanks to self-cleaning / self-ventilating oil circuit
- Electric supply and control voltage on request
- The modular system permits one or several different signal processing methods and additional attachments
- Locking device in OPEN or CLOSED position (optional)

**Testing**

Extensive testing of the actuator with the valves ensures trouble-free operation.

**Application**

- Offshore/onshore, stations, line blocking devices and safety isolating valves
- All models for Ex Zone I
- Ambient temperature -60 °C to +80 °C
- Operating pressure 2 to 12 bar (pneumatics), 10 to 150 bar (high pressure)
- Quick-lock < 15 s to 48" possible

**Design**

- Standard with manual override
- Operated with own medium
- Automatic pipe fracture response (optional)
- With power cut (ESD/optional)
- Also with pressure vessels according to ASME or PED

**Manufacture**

- Control made from seawater-resistant materials
- Pipework and screws made of stainless steel
- Compact, lockable, and seawater-resistant control cabinet

## SCHUCK HYDRAULIC COMPACT ACTUATOR SYSTEM TYPE SHC

### Compact electro-hydraulic control unit

#### AUMATIC

Electronic processing and control of all sensors and actuators as well as communication with the control center.

#### HYDR. CONTROL BLOCK

With all hydraulic components, sensors, and the pump. All Ex-relevant components are located within the pressure-resistant space.

#### EX-D CASING

Pressure-resistant casing with all Ex-relevant components, e.g., solenoid valve, pressure transducer, and/or motor.

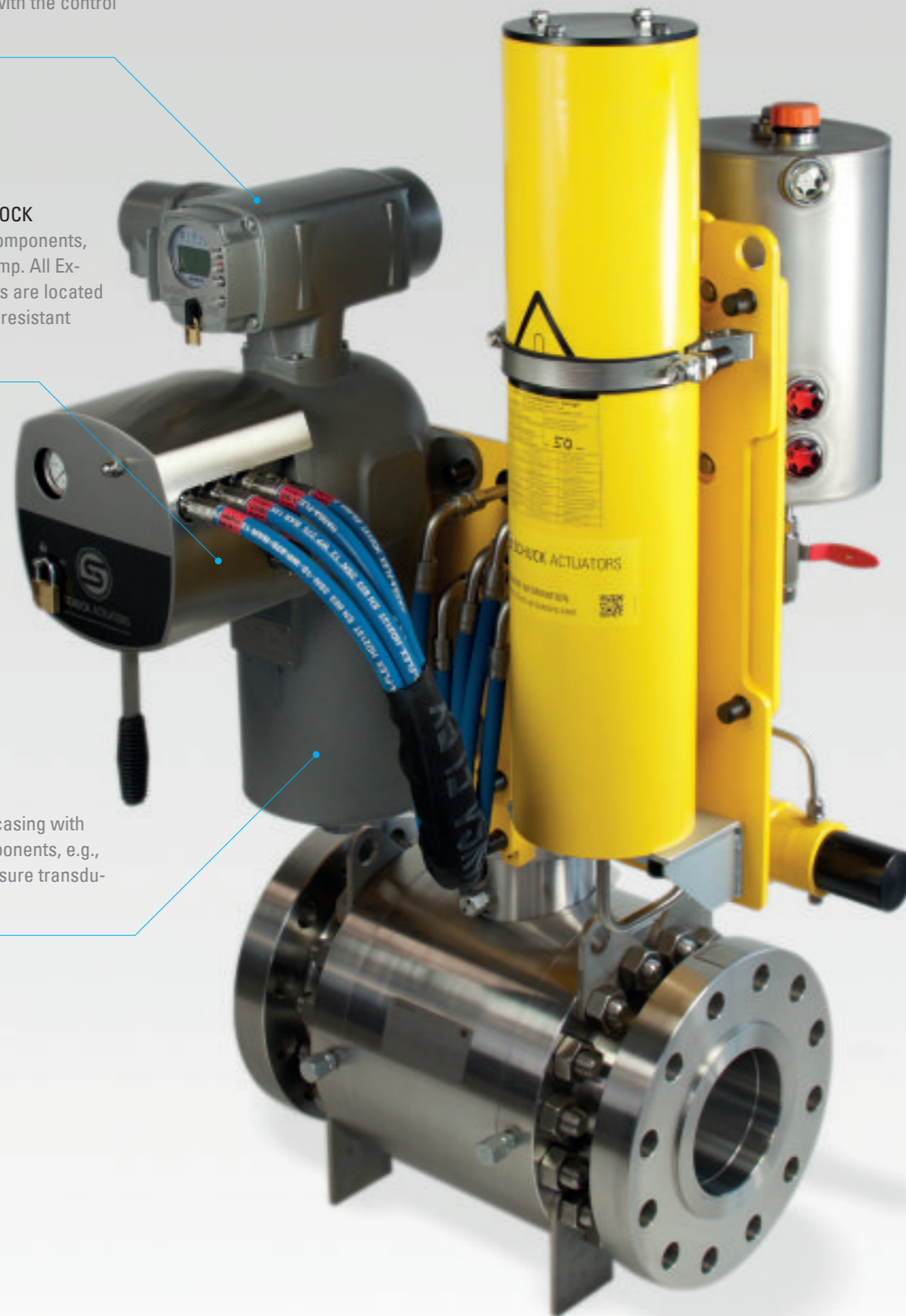

**Left:** Type SHC control with remote control OPEN/CLOSE, incl.

- Torque limitation
- ESD with priority function with automatic reset

**Right:** Hydraulic control block Type SHC with pressure gauge, priority function, isolating valve, and actuator time-throttle valves.

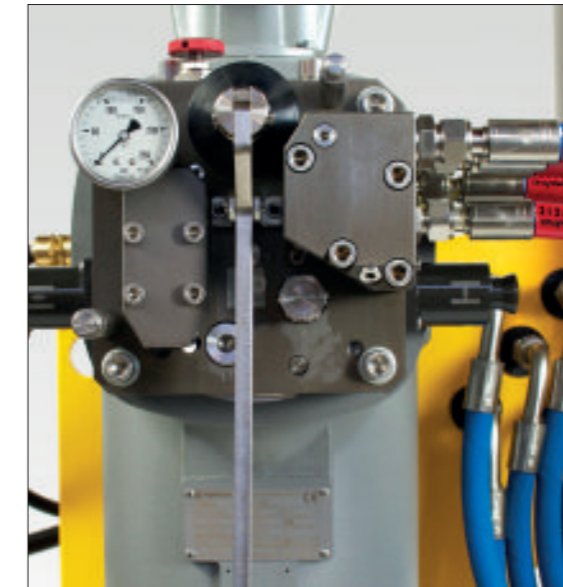

#### Benefits

The compact design results in very few pipelines and screw fittings, no control cabinet required

Cost-effective and highly available thanks to consistent standardization

Integrated seawater-resistant oil return tank with unpressurized, permanent oil level indicator, including electrical oil level monitoring

Emergency manual operation with hand pump  
Automatic reset to normal operation after emergency manual operation (no risk of incorrect operation)

Manual control on site

Remote control

Low-maintenance thanks to self-cleaning / self-ventilating oil circuit

Electronic control with user-friendly interface, extensive programming and setting options

Control via fieldbus and Bluetooth interface (NON-INTRUSIVE).

Locking device in OPEN or CLOSED position (optional)

#### Testing

Extensive testing of the actuator with the valves ensures trouble-free operation.

#### Application

Offshore/onshore, stations, line blocking devices and safety isolating valves

All models for Ex Zone I

Ambient temperature -60 °C to +80 °C

Operating pressure up to 200 bar

Quick-lock < 15 s to 48" possible

#### Design

400 VAC, 3-phase motor, 1.1 kW

With accumulator up to 3 strokes

With CLOSING function in case of power failure (ESD)

Also with pressure vessels according to ASME or PED

#### Manufacture

Control made from seawater-resistant materials

Pipework and screws made of stainless steel

Control with lockable, seawater-resistant hood

# SCHUCK ACTUATOR SYSTEM TYPE C

## Electro-hydraulic

Left: Actuator with control



Right: Type C control with remote control OPEN/CLOSE, incl.  
- Torque limitation  
- Electronic control Type SEC for monitoring and control of the hydraulic actuator control.



### Benefits

The compact design results in very few pipelines and screw fittings

Integrated seawater-resistant oil return tank with un-pressurized, permanent oil level indicator, including electrical oil level monitoring

Emergency manual operation with hand pump

Automatic reset to normal operation after emergency manual operation (no risk of incorrect operation)

Manual control on site

Remote control

Low-maintenance thanks to self-cleaning / self-ventilating oil circuit

Electric supply and control voltage on request

The modular system permits one or several different signal receptors and additional attachments

Locking device in OPEN or CLOSED position (optional)

### Testing

Extensive testing of the actuator with the valves ensures trouble-free operation.

### Application

Offshore/onshore, stations, line blocking devices and safety isolating valves

All models for Ex Zone I

Ambient temperature -60 °C to +80 °C

Operating pressure up to 200 bar

Quick-lock < 15 s to 48" possible

### Design

24 VDC up to 400 VAC, 3-phase motor, 1.1 kW

With accumulator up to 3 strokes, e.g., with power failure (ESD)

Also with pressure vessels according to ASME or PED

### Manufacture

Control made from seawater-resistant materials

Pipework and screws made of stainless steel

Compact, lockable, and seawater-resistant control cabinet

# SCHUCK ACTUATOR SYSTEMS

## Signal receptor accessory

Left: Type KY control with remote control OPEN/CLOSE, incl.  
- Torque limitation  
- Automatic pipe fracture response with manual reset and optional adjustment set



Right: Type G control with remote control OPEN/CLOSE, incl.  
- Locking device (OPEN)  
- Torque limitation  
- ESD solenoid valve  
- Pipeline pressure monitoring

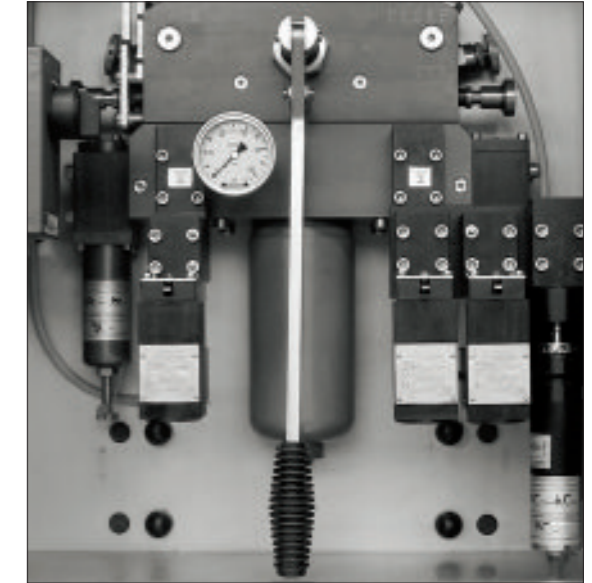

### Automatic pipe fracture response

The pipe fracture automation (line break) is mounted on the base controller via an intermediate plate in modular design.

### Function Type KY

In addition to the basic control tasks, this closes the ball valve in case of a ruptured pipe. Temporary, minor pressure fluctuations and slow, continuous pressure drops do not trigger an automatic pipe fracture response. The automatic pipe fracture response triggers based on the pressure drop velocity in the pipeline in relation to the pressure drop duration. The actuator can no longer be used once the pipe has burst. Automatic pipe fracture response is available with automatic or manual unlocking.

The automatic pipe fracture response can be checked and adjusted locally at any time using a compact adjustment set.

Thanks to the consistent block design, additional signal receptors can be retrofitted quickly and easily.

Additional signal recording can be optionally selected with priority function.

The priority function ensures that the emergency command has priority over all other movement commands, including the hand pump function.

### Closing in case of pressure loss or loss of power

Two additional valves are mounted on the base controller via an intermediate plate in order to be able to receive these signals.

### Function Type G

In addition to the basic control tasks, this closes the ball valve in case of a power failure and/or a loss of pressure. The actuator can no longer be used if the power or pressure fails. The CLOSING function for power/pressure loss is available with automatic or manual unlocking.

Thanks to the consistent block design, additional signal receptors can be retrofitted quickly and easily.

Additional signal recording can be optionally selected with priority function.

The priority function ensures that the emergency command has priority over all other movement commands, including the hand pumps function.



# SCHUCK ACTUATOR SYSTEMS

## Additional attachments (excerpt)



### D TORQUE LIMITER

The torque limiter protects the actuator and the downstream components against excessive output torques. Once it has triggered, the torque limiter switches off automatically as soon as the pressure drops to a permissible value. Torque limiters are primarily used in connection with double-acting cylinder actuators.



### L LIMIT SWITCH

The limit switch is a compact, closed unit, which was specially developed for the Schuck actuator. The limit switch prevents moving parts from being outside of the actuator. The limit switch contains four mechanical toggle switches with which the travel commands are cancelled in the end position and which can signal the end positions. Inductive proximity switches, 4-20 mA positioners, potentiometers, or a combinations thereof can be used alternatively. All electrical components are suitable for Ex Zone I.



### C SOLAR PACKAGE

To operate actuators, actuator control, and Type SEC electronic controllers independently, stand-alone voltage supply via a solar package consisting of a solar panel and a battery can be used.

The solar package is approved for use in explosive areas.

The solar package is designed for up to 10 days of stand-alone operation and is equipped with a solar controller, voltage and charge monitoring.

The orientation and inclination of the panels is individually adapted to the local conditions.



### Q ENERGY STORAGE DEVICE

Using an energy storage device, it is possible to repeatedly actuate the ball valve even when the control power has failed. The size and design of the energy buffer varies depending on the customer requirements and the conditions of use.

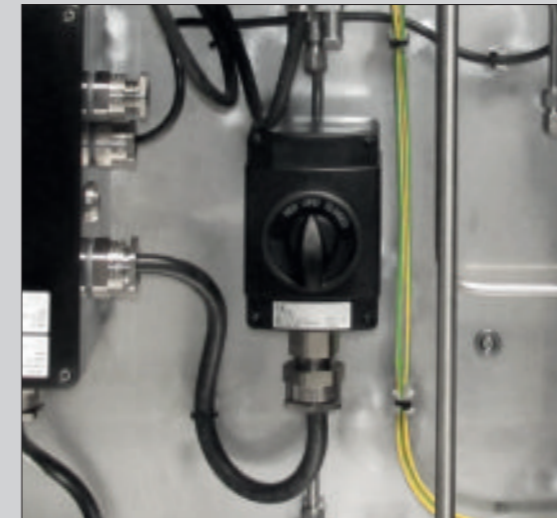

### O ON-SITE SWITCH

The electrical control of the solenoid valves and the resulting, unintended run command from the control room can be switched off by maintenance personnel for maintenance purposes directly on the actuator via an on-site switch.

The on-site switch features the following positions: 0-LOCAL-REMOTE.

The on-site switch can be locked with a padlock in each position.

The design of the on-site switch can be customized according to customer specifications.



### Y HYDRAULIC MANUAL OVERRIDE

The hydraulic manual override allows for pneumatic and/or spring-return actuator systems to be driven to the desired position even if the power has failed. The hydraulic manual override can be retrofitted at any time.

# SCHUCK ACTUATOR SYSTEMS

## Electronic controls

Left: Electronic control system Type SEC (Schuck Electronic Control) for controlling all actuator systems with integrated pipeline pressure monitoring



Right: Electronic control Type SEL (Schuck Eco Lineguard) for stand-alone pipeline monitoring



### Product benefits SEC

- LED display of operating states
- Integrated lighting
- Low actuation power
- Electrical supply and control voltage according to customer specifications
- Specific system program
- Operation via six capacitive function keys
- Update via Bluetooth possible (NON-INTRUSIVE)
- Modbus interface available
- Parameter change via function keys (NON-INTRUSIVE)
- Manual control on site
- Remote control / on-site control (lockable)
- Multi-language menu
- Monitoring of: Runtime, oil level, line break, system pressure, phases, short circuit, pipeline pressure
- Customization possible

### Applications SEC

- Offshore/onshore, stations, line blocking devices and safety isolating valve
- All versions for Ex Zone I
- Ambient temperature -60 °C to +80 °C

### Design SEC

- Power supply: 24 VDC... 400 VAC
- Control: 24 VDC...230 VAC
- Protection class: IP66
- Ex protection: Ex db IIB T6
- Main switch with three positions 0 – Local – Remote (lockable)
- Operation via six capacitive function keysP

### Product benefits SEL

- Display showing operating states
- Integrated lighting
- Extremely low power consumption
- Stand-alone with integrated battery (about 2 years)
- External power supply possible
- Specific system program
- Operation, update, parameter changes via Bluetooth (NON-INTRUSIVE)
- Modbus interface available
- Multi-language menu
- Monitoring: battery, pipeline pressure, short circuit and line break
- Customization possible

### Application SEL

- Offshore/onshore, stations, line blocking devices and safety isolating valves
- All versions for Ex Zone I
- Ambient temperature -60 °C to +80 °C

### Design SEL

- Power supply: internal battery, external 24 VDC (on customer request)
- Control: Modbus
- Protection class: IP67
- Ex protection: Ex db IIC T4
- SIL 2 certified

### Testing SEC and SEL

Extensive testing of the actuator with the valves ensures trouble-free operation.

### Manufacture SEC and SEL

- Aluminum casing (painted)
- Cable gland made of brass

# SCHUCK ACTUATOR SYSTEMS

## Type code for actuator systems

### Schuck Type code for actuator systems

Basic control		Remote control		Signal receptor			Additional attachments	
				CLOSING	for	OPENING		
0	without	0	electrically CLOSE/OPEN	0	without	0	A	Locking device
A	Gas-over-oil circulation system (only as spare part)	1	pneumatically CLOSE/OPEN	1 1)	Line break (gas)	1 1)	B	Pressure controller
C	Electrohydraulic with motor pump and elec. / electr. Control	2	electrically OPEN	- -	Differential pressure exceeded (blocks ON actuation)	2 1)	C	Solar package
G	Gas-over-oil without leveling	3	electrically CLOSE	3 1)	Pressure point overrun	3 1)	D	Torque limitation
K	Direct gas / pneumatic	4	pneumatically OPEN p = 0 => CLOSE	4 1)	Pressure point underrun	4 1)	E	Positioner
KY	Direct gas / pneumatic with internal hydraulic manual override	5	pneumatically CLOSE p = 0 => OPEN	5 1)	Control pressure failure	5 1)	F	Cordless remote control
M	Underwater hydraulic	6	Manual operation	6 1)	Power failure	6 1)	G	Electronic line guard
W	Unterwasser pneumatisch	7	electrically CLOSE/OPEN p = 0 => OPEN	7 1)	Power applied	7 1)	H	Seat ring pressing for KH
SHC	Electrohydraulic Compact with motor pump and Auma electr. Control	8	electrically CLOSE/OPEN p = 0 => CLOSE	8 1)	Spannungseintritt	8 1)	I	External terminal box
X	Electrohydraulic Compact with left / right running motor pump	9	electrically CLOSE/OPEN p = 0 => CLOSE, without manual override	9 1)	Manual emergency	9 1)	J	Control cabinet heating
		10	hydraulically CLOSE/OPEN	10 nur h	Temperature overrun (safety fuse)	10 nur h	K	Pneum./hydr. limit switch
		11	electrically CLOSE/OPEN control signals: Power failure Closed Power applied Open	11 1)	Pipe break (liquid)	11 1)	L	Electric limit switch
		12	electrically CLOSE/OPEN control signals: Power failure Open Power applied Closed	12 1)	Line break (electric for gas/liquid)	12 1)	M	Manual emergency gear
				13 1)	Line break (with hydraulic transmission)	13 1)	N	Auxiliary power switch
							O	ON SITE / REMOTE switch
							P	Pressure equalization system
							Q	Energy storage device
							R	Adjustment set for auto. pipe fracture response
							S	Automatic seat ring control
							T	Hydraulic end position cushioning
							U	Rechargeable battery pack
							V	Partial valve stroke system
							W	Cathodic corrosion protection
							X	Electrical control
							Y	Hydraulic manual override
							Z	Fire protection equipment
							A1	Switch cabinet with door sensor
							B1	Switch cabinet with door lock
							C1	Hand pump with sensor
							D1	-
							E1	-
							F1	-

#### Example on how to use the type code: G0-1ap7hs-0-LQ

G » Actuator system: "Gas over oil without leveling"  
 0 » Remote control: "electrically CLOSE/OPEN"  
 1ap » 1. Signal CLOSED for "pipe break (gas)" with "automatic release a" and "priority function p"  
 7hs » 2. Signal CLOSED for "high-pressure time-out" with "manual unlocking h" and option "s"  
 0 » Signal OPEN: "Without"  
 LQ » Additional attachment: "Limit switch" + "energy storage"

#### 1) Signal receptor abbreviation

Signal receptor, release: a = automatic, h = manual, e = electrically  
 Signal receptor, priority function: p = signal with priority function  
 Signal receptor, optional: s = electric switch for monitoring the valve position

**Important note:** Not all combinations of primary and remote control, signal receptors, and additional attachments are possible. Please observe the technical description of the respective actuator system.

## SCHUCK PRODUCT OVERVIEW

Quality and safety - More Schuck products that impress across the board.



### G-VALVE

Fully welded shut-off valve for maintenance-free over- and under-floor use in long distance pipelines, on stations, and platforms.

- » Low temperature -60 °C to +50 °C
- » Normal temperature -29 °C to +50 °C
- » Higher temperature -29 °C to +160 °C
- » Suitable for use with natural and sour gas, oil, oil with sulfur, hot and cold water
- » With flange ends, spigot ends, or welded flange ends
- » Available from 1/2" to 60"
- » Load capacity up to CLASS 1500
- » Operating range -60 °C to +160 °C



### NEW INSULATING JOINT TYPE SHD - GAS APPLICATION

Insulating joint with spark gap used to interrupt the metallic conductivity of pipelines.

- » Integrated and patented spark gap
- » Cathodic corrosion protection possible
- » Ready to install, friction-locked and fully welded design
- » No loss of preload force
- » Homogenous seamless external insulation
- » Resistant to deflection
- » Symmetric or asymmetric design
- » Optional brackets for external spark gap
- » ATEX and Firesafe design available
- » Different external and internal coatings possible
- » Designed according to AD instructions or ASME
- » Different sealing and insulating materials available

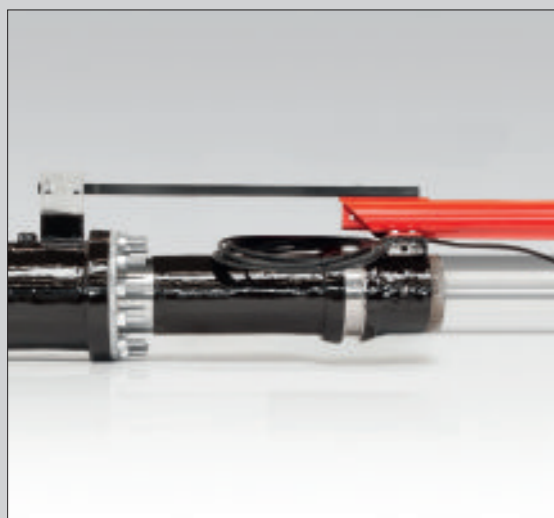

### EXPANDER TYPE SDS

Maintenance-free, self-sealing compensator.

- » Two separately operating sealing sets
- » No retightening of the seals and gaskets required
- » High bending moments possible for flexing/bending
- » Defined separation of both seals» Combined wiper system
- » Permanent lubrication of the sliding surfaces
- » Separate testing of sealing systems possible
- » Easy to adjust
- » Rated for pressures up to 100 bar
- » Can be scraped (in one direction)
- » Ready to install component
- » Reusable

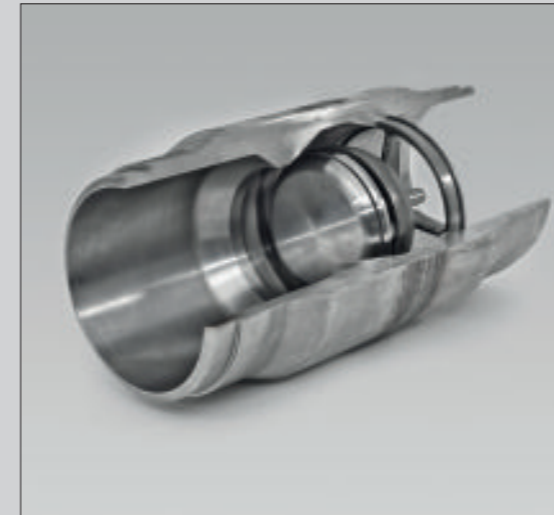

### NOZZLE CHECK VALVE TYPE DRV

Maintenance-free, low-noise valve for the safe prevention of backflow.

- » Flow-optimized shape with axial valve disk
- » Optimum hydraulic behavior
- » Broad operating range (Q min/Q max)
- » Maintenance-free. Not sensitive to impurities.
- » Vertical and horizontal mounting position possible
- » Different versions / construction lengths
- » For the prevention of medium backflow
- » Applications such as compressor stations
- » Sealing technology: PMSS (primary metallic/secondary soft sealing)
- » Low-noise and low-impact operation
- » Fire Safe in compliance with ISO 10697 / API 607
- » Cladding in the sealing area



### PIG TRAPS TYPE SMO

For reliable pig launching in a pipeline system. Applications for the Schuck pig launchers range from different media such as oil and gas up to a wide range of nominal diameters and pressure ratings.

- » Welded steel construction with manually operated quick-action bayonet closure
- » Choice of flange or welded joint
- » With pig sensor
- » Corrosion protection as required
- » In accordance with drawing specified by customer, otherwise standard as shown in sketch
- » Surfaces sand-blasted (optional)

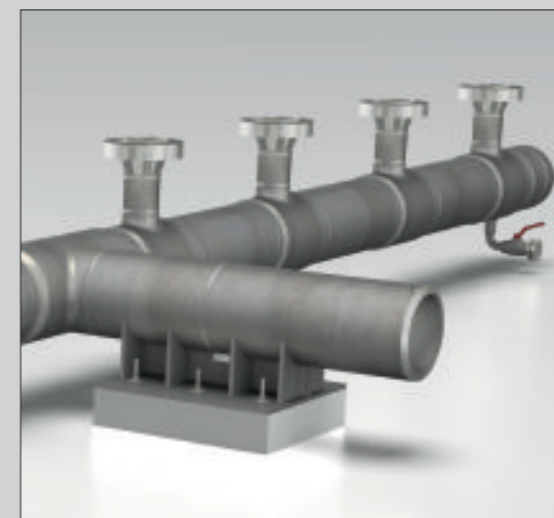

### COLLECTORS AND T-PIECES

Together with customer-specific requirements, Schuck custom-built fittings such as collectors and distributors also meet all manufacturing and testing conditions from the specified rule groups for use in pipelines and plant construction.

- » Customized individual solutions by customer request
- » Design, calculation construction, and production from a single source at Schuck
- » Realization of nominal widths up to 60"
- » Max. nominal pressure 230 bar
- » Primarily used for gas, but can also be used for other media
- » Processing and testing equipment allow for accommodation of various corrosion protection systems

## SCHUCK SERVICES

Customer service, repairs, and training for Schuck and third-party products

### Left page, top left:

Schuck service - Arrival of Schuck service specialists for maintenance work.

Left page, top right: Comprehensive range of services from repairs through to training and various services.

Right page: Onshore and offshore - Individual repairs or comprehensive planning and takeover of all incidental work.



### SUSTAINABLE USE

The Schuck Service team provides preventive maintenance and servicing, repairs, and modifications as well as the delivery of spare and new parts for ball valves, actuators, and controls: Onshore and offshore.

The main focus of the worldwide on-site services are the products from Schuck. But the wide-ranging expertise and extensive system knowledge allow us to reliably support other products as well.

The working life of complex systems can be greatly extended through preventive maintenance and repair. Schuck Service technicians can provide tailor-made, complete packages - from condition analysis to comprehensive on-site consultations.

Framework agreements are available as an economical solution to individual servicing and maintenance requirements, and customers also have access to the stocks of spare parts. Whether individual repair jobs or comprehensive planning and handling of all incidental processes: from installation at the site, the supply of replacement equipment and auxiliary machinery, and of course all the tests and approvals required before the equipment goes into service - the Schuck Service team covers all requirements.

### SERVICES

#### Repair and maintenance

- Condition analysis
- Maintenance plans
- Worldwide on-site maintenance

#### Repairs

- Project planning
- Logistics planning
- Procurement, preparation, and manufacture of spare parts
- Repairs
- Recommissioning

#### Conversions

- Project planning
- Logistics planning
- Procurement, manufacture, and conversion of parts
- Reconstruction
- Commissioning

#### Spare and new parts

- Spare parts
- New parts
- Preparation

#### Consulting and training

- Modification consulting
- Realization consulting
- Product training
- Startup procedure training
- Service training



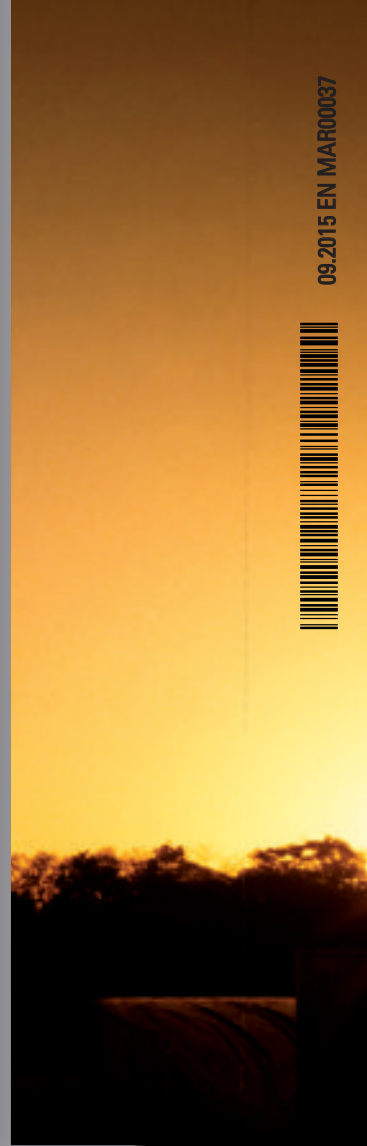
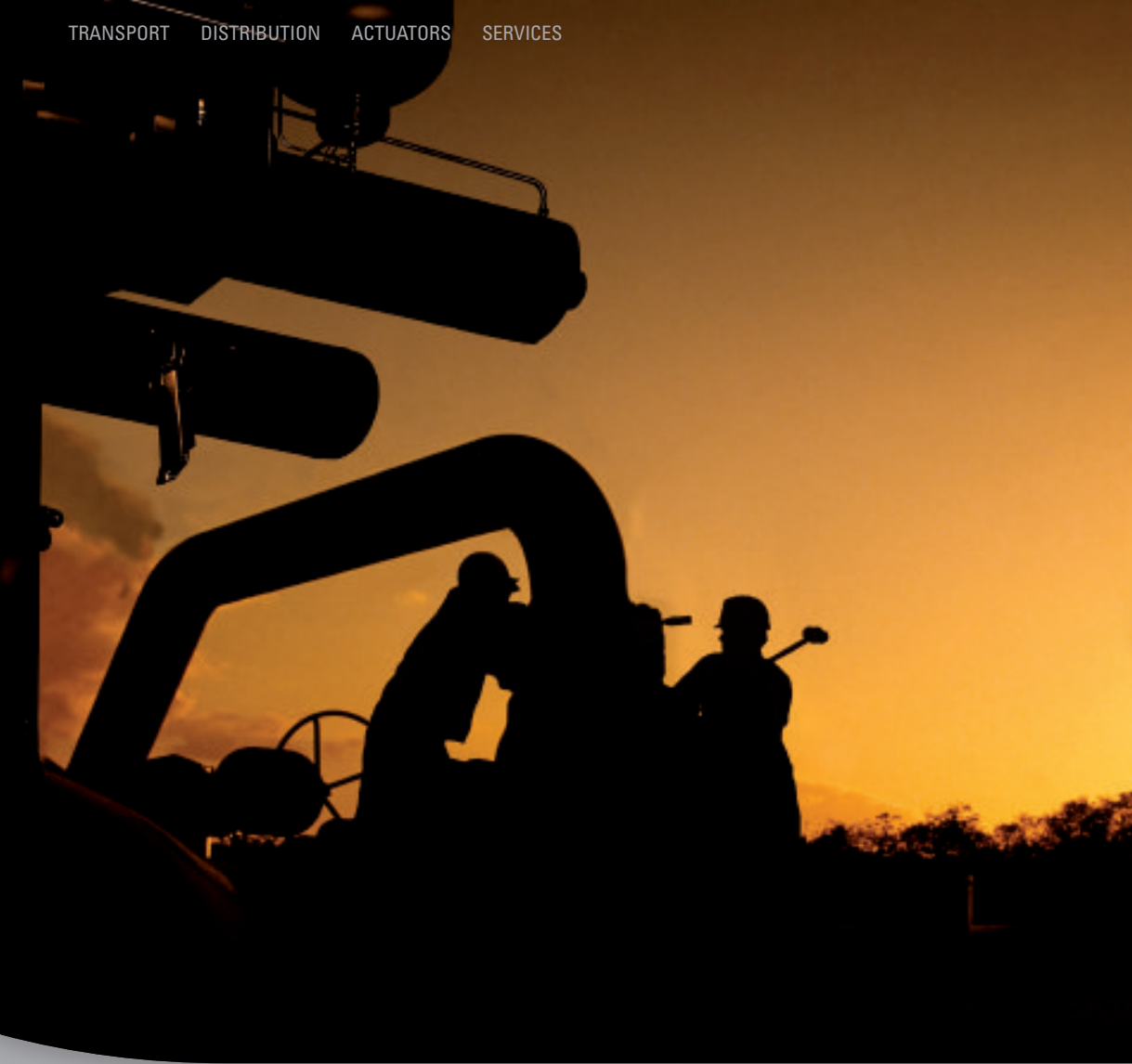

09.2015 EN MAR00037

**SCHUCK GROUP**

Franz Schuck GmbH  
Daimlerstraße 5-7  
89555 Steinheim, Germany

Fon +49. (0) 7329. 950 -0  
Fax +49. (0) 7329. 950 -161

info@schuck-group.com  
www.schuck-group.com

We manufacture and distribute components for the connection of pipeline systems in more than 50 countries, with five international offices, and more than 40 years of experience.

Would you like to find out more about a specific product?  
Call us or visit us on our website at [www.schuck-group.com](http://www.schuck-group.com).

Please direct your inquiry to:

INFO@SCHUCK-GROUP.COM  
SERVICE@SCHUCK-GROUP.COM  
ERSATZTEILE@SCHUCK-GROUP.COM



**SCHUCK GROUP**

DESIGN  
ENGINEERING  
MANUFACTURING  
MADE IN GERMANY